



Metalastik® type Metacone™ and Novibra® type HK

A range of mountings designed for high load capacity with relatively large static deflections. The high loading for a given size is achieved by utilising the rubber to best advantage in shear and compression. Normally, mountings are assembled with overload and rebound washers to control and limit movement of the suspended equipment under shock loads. Centre fixing bolts should be torque tightened to the recommended values.

Applications include suspensions for:

- Off-road and road vehicle engines
- Marine Engines
- Vehicle Cabs
- Oil Tanks/Tankers
- Mobile applications

Type	Art.No.	Max vert. load (kg)	Weight (kg)
Metacone™	17-0189-45 (45° IRH)	145	0.28
	17-0189-70 (70° IRH)	290	0.28
	17-0241-45 (45° IRH)	62	0.18
	17-0241-60 (60° IRH)	122	0.18
	17-0248-45 (45° IRH)	95	0.19
	17-0248-60 (60° IRH)	190	0.19
	17-0277-45 (45° IRH)	125	0.56
	17-0277-60 (60° IRH)	230	0.56
	17-0379-45 (45° IRH)	35	0.12
	17-0379-60 (60° IRH)	70	0.12
	17-0341-45 (45° IRH)	160	0.54
	17-0341-60 (60° IRH)	300	0.54
	17-0341-70 (70° IRH)	430	0.54
	17-0311-45 (45° IRH)	125	0.58
	17-0311-60 (60° IRH)	220	0.58
17-1691-45 (45° IRH)	72	0.44	
17-1691-60 (60° IRH)	144	0.44	
HK 60-40	2256900 (40° IRH)	90	0.24
HK 60-50	318390 (50° IRH)	115	0.24
HK 60-60	2256910 (60° IRH)	180	0.24
HK 60-70	318380 (70° IRH)	250	0.24

Features

A compact fail safe design, available for a wide range of loadings with in some cases alternative fixings. Cutouts in rubber section on various sizes provide different vertical/horizontal stiffness ratios. Most sizes can be supplied complete with overload and rebound washers.

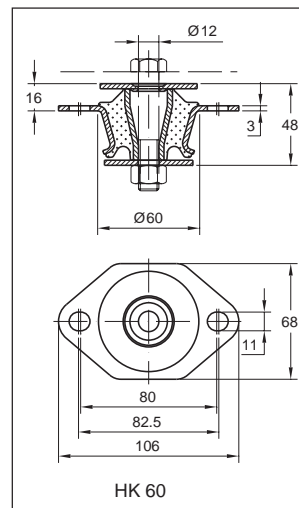
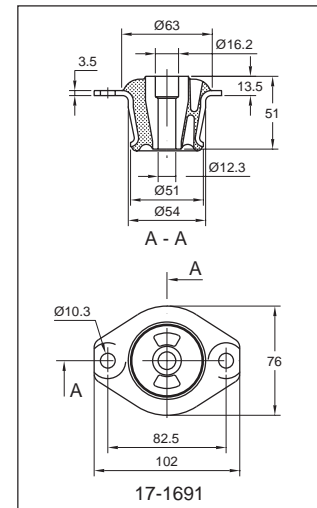
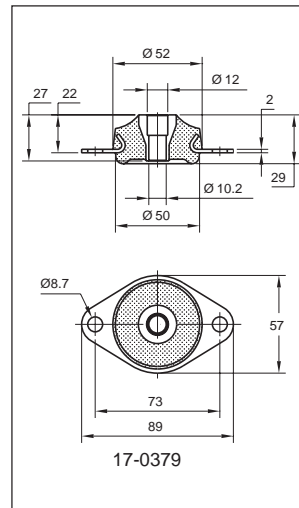
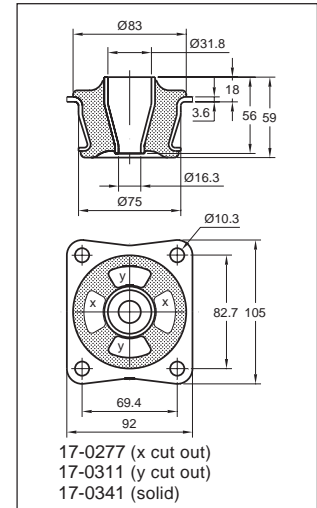
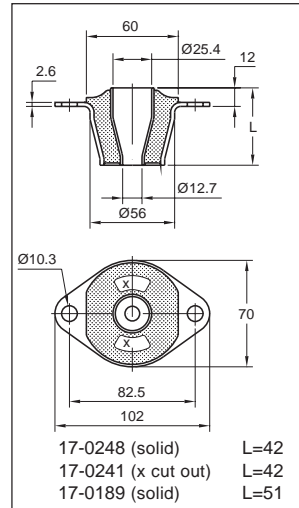

Type	Cone mount	Top washer Art.No.	Bottom washer Art.No.
Metacone™	17-0189	336050	336000
	17-0241	336050	336000
	17-0248	336050	336000
	17-0277	336060	336080
	17-0379	336070	336070
	17-0341	336060	336080
	17-1691	336110	336120
HK	HK 60	318490	318500

Metalastik® type Metacone™ and Novibra® type HK

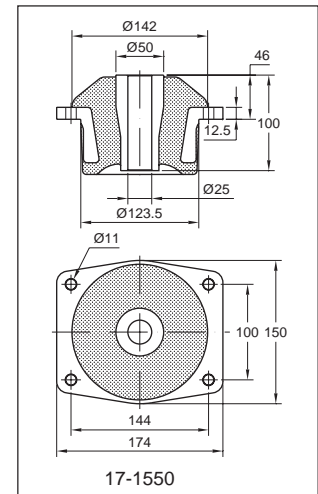
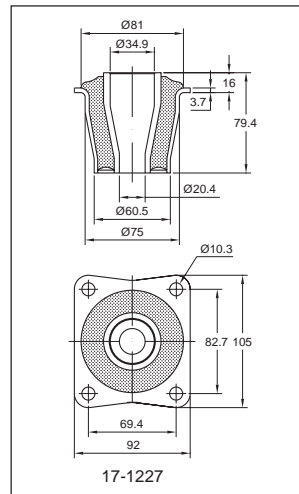
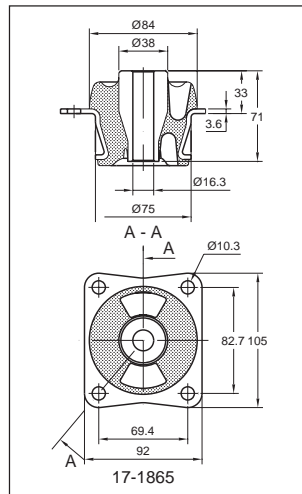
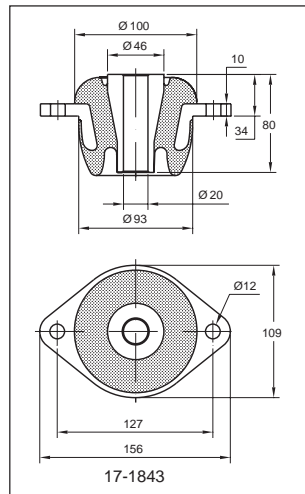
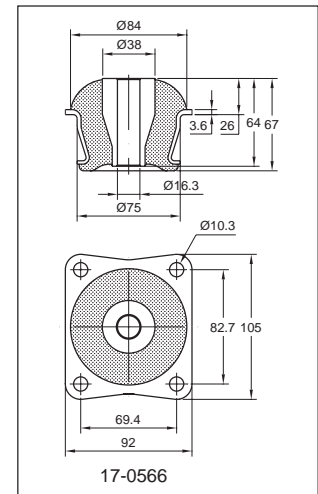
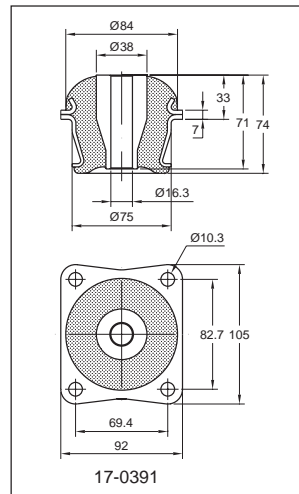
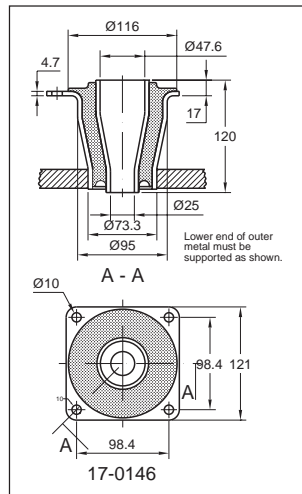

Type	Art.No.	Max vert. load (kg)	Weight (kg)
Metacone™	11-1009-45 (45° IRH)	140	0.59
	11-1009-55 (55° IRH)	200	0.59
	17-0391-45 (45° IRH)	290	1.1
	17-0391-60 (60° IRH)	500	1.1
	17-0391-70 (70° IRH)	610	1.1
	17-0566-45 (45° IRH)	200	0.82
	17-0566-60 (60° IRH)	380	0.82
	17-0566-70 (70° IRH)	525	0.82
	17-1227-45 (45° IRH)	560	1.1
	17-1227-60 (60° IRH)	1000	1.1
	17-1550-45 (45° IRH)	720	4.4
	17-1550-60 (60° IRH)	1250	4.4
	17-1843-45 (45° IRH)	320	1.7
	17-1843-60 (60° IRH)	600	1.7
	17-1865-55 (55° IRH)	180	0.86
	17-0146-45 (45° IRH)	950	2
	17-0146-60 (60° IRH)	1700	2
HK 600-40	2256940 (40° IRH)	940	1.0
HK 600-60	2256950 (60° IRH)	1700	1.0

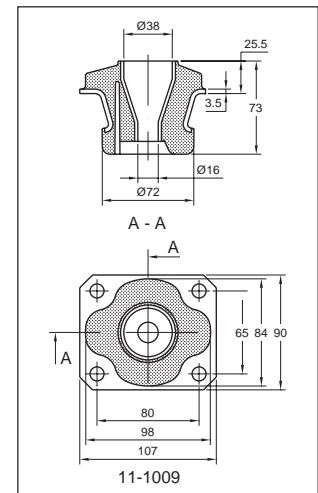
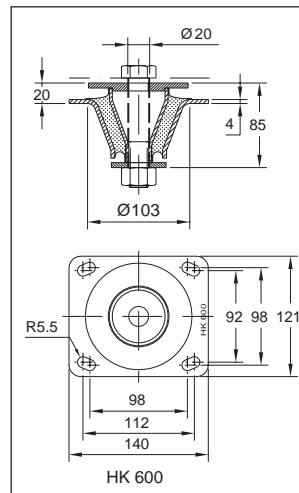

Type	Cone mount	Top washer Art.No.	Bottom washer Art.No.
Metacone™	11-1009	336080	336080
	17-0391	336080	336080
	17-0566	336080	336080
	17-1227	336040	336020
	17-1550	336100	336100
	17-1843	336090	336090
	17-1865	336080	336080
	17-0146	336030	336010
HK	HK 600	2230570	2230560

Top and bottom washers

Overload and rebound washers (top and bottom) are necessary to limit maximum movement in the event of shock loading.

**Type A
Steel Washer**

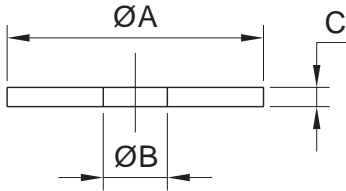

**Type B
Top Stepped Steel Washer**

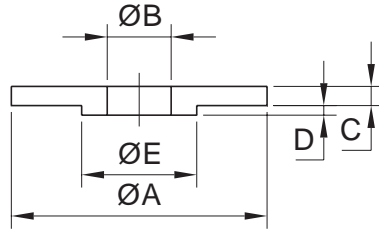

**Type C
Rebound Washer with Rubber**

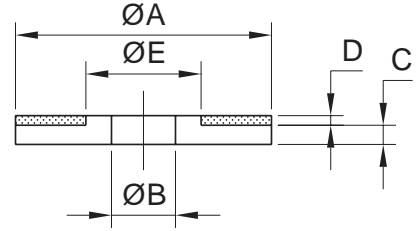

Washer

Designation	Art.No.	Type	Dimensions in mm				
			A	B	C	D	E
Washer 50x12C	336000	C	50	12	3	3	28.5
Washer 95x24C	336010	C	95	24	8	6	38
Washer 67.5x20C	336020	C	67.5	20	5	5	30
Washer 116x24B	336030	B	116	24	8	4	47
Washer 80x20B	336040	B	80	20	6	3	34.5
Washer 55x12B	336050	B	55	12	5	2.5	25
Washer 80x16B	336060	B	80	16	6.5	3	31.5
Washer 50x10A	336070	A	50	10	4		
Washer 80x16A	336080	A	80	16	5		
Washer 100x20A	336090	A	100	20	6		
Washer 139x24A	336100	A	139	24	10		
Washer 55x16B	336110	B	55	16	5	2,7	25
Washer 51x16A	336120	A	51	16	4		
Washer 57x16B	318490	B	57	16	3	1.5	22
Washer 52x16A	318500	A	52	16	3		
Washer 110x20B	2230570	B	110	20	5	3	52.5
Washer 55x20A	2230560	A	55	20	5		

Recommended tightening torque for center fixing bolts	
Thread size	Torque (Nm)
M10	25
M12	40
M16	60
M20	120
M24	200

Metacone™ and HK on page 40

Type	Cone mount	Top washer Art.No.	Bottom washer Art.No.
Metacone™	17-0189	336050	336000
	17-0241	336050	336000
	17-0248	336050	336000
	17-0277	336060	336080
	17-0379	336070	336070
	17-0341	336060	336080
	17-0311	336060	336080
	17-1691	336110	336120
	HK	HK 60	318490

Metacone™ and HK on page 42

Type	Cone mount	Top washer Art.No.	Bottom washer Art.No.
Metacone™	11-1009	336080	336080
	17-0391	336080	336080
	17-0566	336080	336080
	17-1227	336040	336020
	17-1550	336100	336100
	17-1843	336090	336090
	17-1865	336080	336080
	17-0146	336030	336010
	HK	HK 600	2230570