

● RA & Fail Safe EF



Novibra[®] type RA and Metalastik[®] type Fail Safe EF

For effective isolation of vibration and noise on machines with rotating movements, e.g.

- Compressors
- Combustion engines
- Generators
- Converters
- Pumps
- Industrial and marine gen-sets
- Fans

Also suitable for use with presses, punches and other workshop machines.

Features

RA and EF uses the rubber profile in shear and compression, obtaining good vertical flexibility with the advantage of horizontal stability. For normal speeds of approx. 1500 rpm, the RA and EF type provides a degree of isolation of 75-85%. For better isolation, the alternative RAEM or M can be chosen.

Its unique construction and the latest production methods make Novibra[®] type RA and EF a high performance mounting having a number of advantages:

- Rubber features are utilised effectively combining compression and shear.
- Wide load rating options, 40-2100 kg.
- Corrosion protected to cope with arduous environments on land or marine applications (Fe/Zn8C as per ISO 2081).
- Fitted as standard with an integral fail-safe design device with resilient stop, making RA and EF ideal for use in mobile applications. The RA/EF-mounts can accommodate occasional shock loads to 5 g reference to the weight in hardness 60° IRH. The mount will withstand shock loads up to 2 g without plastic deformation.
- Clear and durable product marking so that mountings can be identified even after several years in operation.
- Domed shape cover to protect against oil contamination.

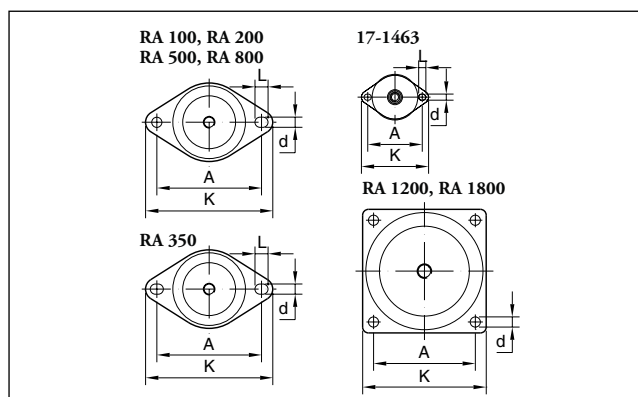
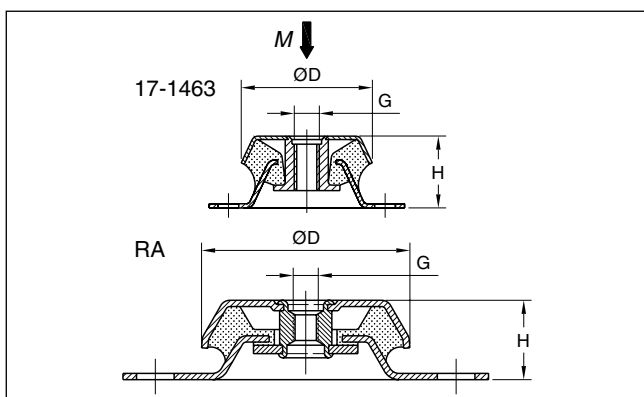

Type	Part no.		Dimensions in mm							Weight (kg)	M-Max (kg)	
	40° IRH	60° IRH	D	A	H	K	d	L	G		40° IRH	60° IRH
RA 100/M10	10-00106-01	10-00107-01	79	110	30	130	9	12	M10	0.33	105	240
RA 100/M12	10-00166-01	10-00167-01	79	110	30	130	9	12	M12	0.33	105	240
RA 200/M10	10-00110-01	10-00111-01	94	124	35	150	10	15	M10	0.47	180	280
RA 200/M12	10-00165-01	10-00091-01	94	124	35	150	10	15	M12	0.47	180	280
RA 350/M12	10-00172-01	10-00173-01	101	140-148	38	175	14	18	M12	0.74	250	450
RA 350/M16	10-00112-01	10-00113-01	101	140-148	38	175	14	18	M16	0.74	250	450
RA 500	10-00116-01	10-00117-01	123	158	42	192	14	18	M16	1.02	450	700
RA 800	10-00118-01	10-00119-01	144	182	46	216	14	18	M16	1.59	750	1300
RA 1200	10-00154-01	10-00155-01	161	140	58	170	14		M20	2.19	900	1600
RA 1800	10-00156-01	10-00157-01	181	160	66.5	190	14		M20	2.33	1300	2100
Fail Safe EF												
17-1463-35		10-00503-01								0.22		55
17-1463-45		10-00504-01	65	76.2	35	94	8.5	10	M12	0.22		80
17-1463-60		10-00505-01								0.22		170
17-1463-70		10-00506-01								0.22		240

Note: The natural frequencies and degrees of isolation are based on dynamic characteristics of the mountings.

Load
 per mounting (kg)

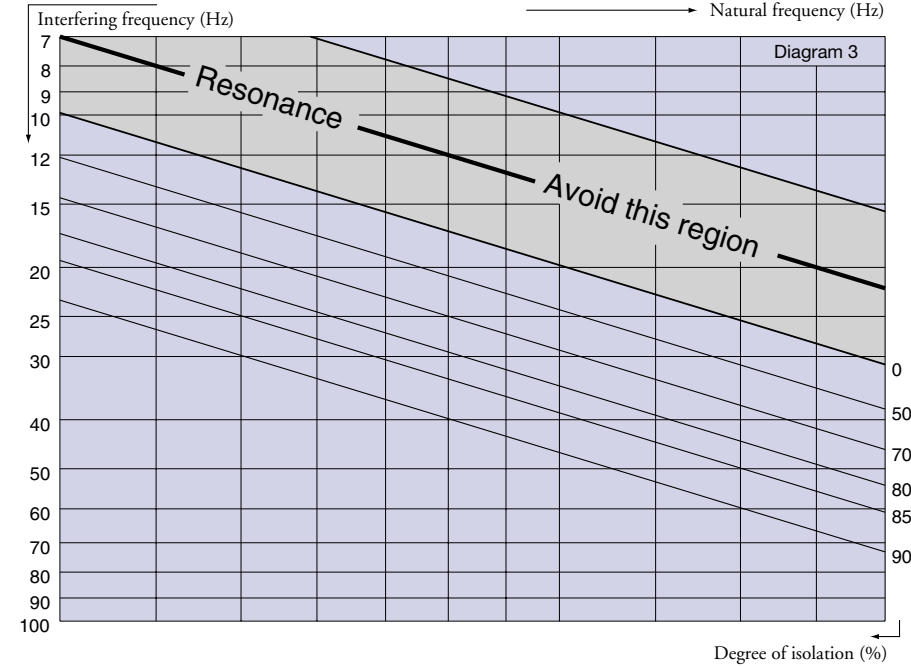
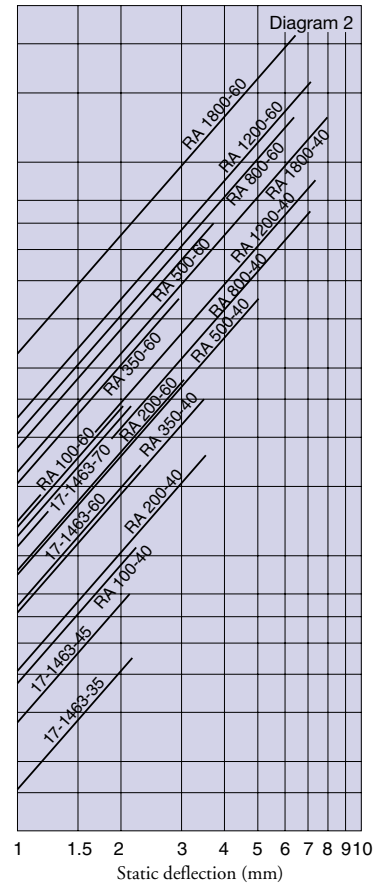
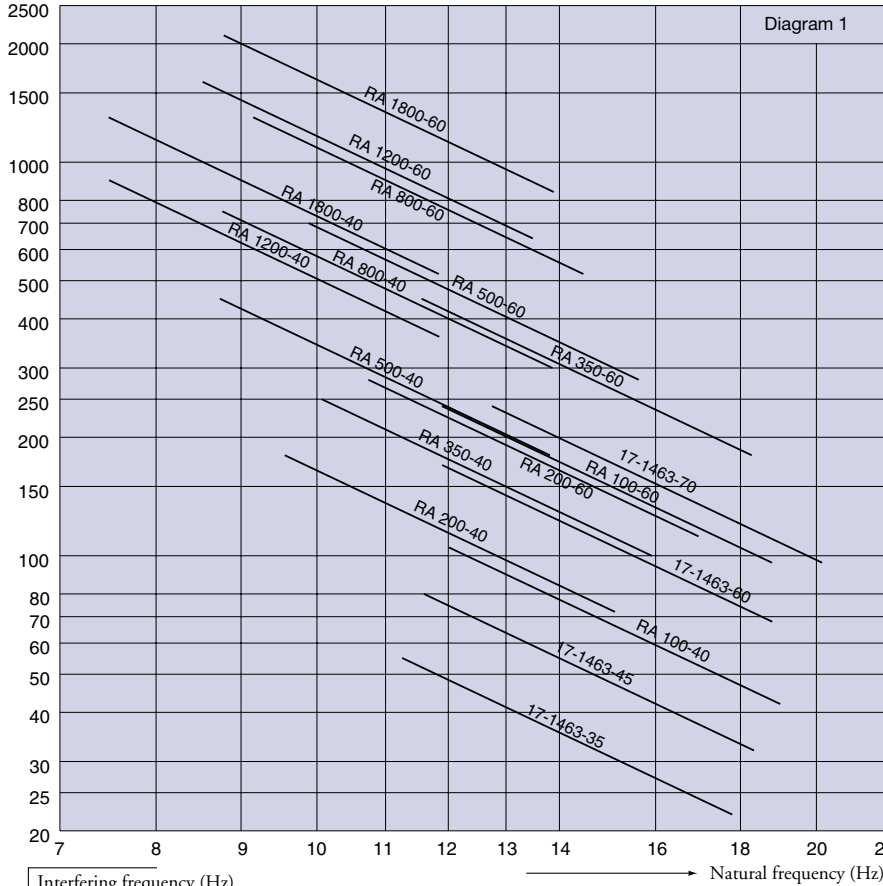

To select correct mounting, following data are needed:
 1) Load per mounting (kg)
 2) Interfering frequency (Hz)
 (Hz = rpm / 60)
 Select correct load line in diagram 1 and correct interference line in diagram 3. The load line intersects with required type of mounting.
 Connect this intersection point vertically down to the interference line in diagram 3. Here, on the sloping curve, the isolation degree is indicated.
 For static deflection, see diagram 2.

